

Shift Linkage Adjustment

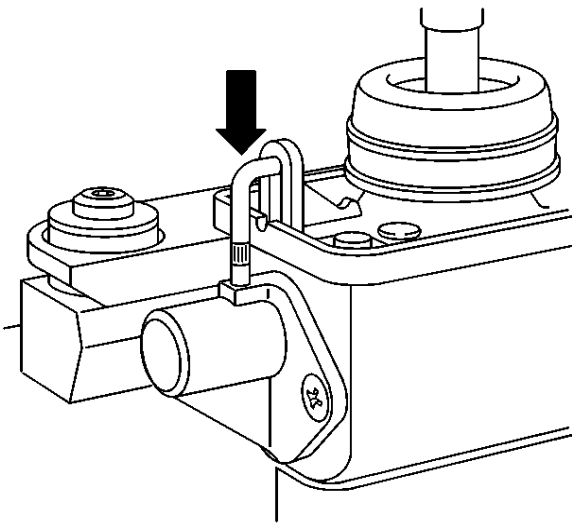

1. Apply the parking brake.
2. Remove the shifter closeout boot.
3. Place the shifter into NEUTRAL.
4. Press down to engage the shifter neutral lock pin.

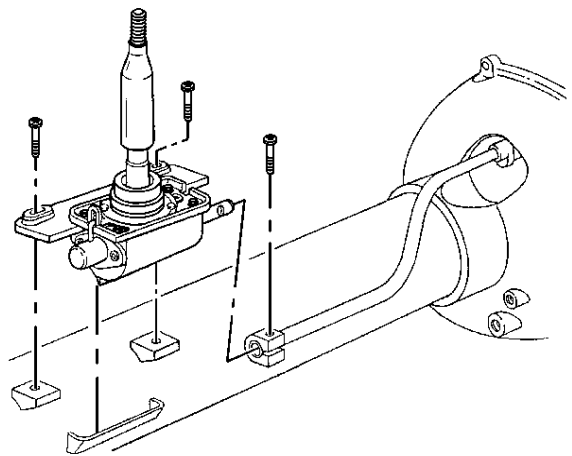

5. Loosen the transmission shift rod clamp bolt.
6. Loosen the shifter mounting bolts.
7. Check that the shifter locator (on the underside of the shift control) is installed into the shifter bracket on the side of the driveline support assembly.

8. Tighten the shifter mounting bolts to 30 N·m (22 lb ft).
9. Tighten the transmission shift rod clamp bolt to 30 N·m (22 lb ft).

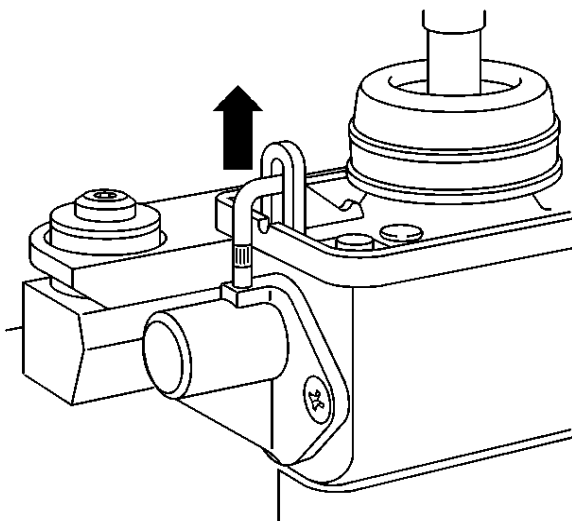

10. Lift to release the shifter neutral lock pin.
11. Install the shifter closeout boot.
12. Release the parking brake.

Note: 4 quart capacity of Dexron III